

# MBTF10 - 1,0xD

Verktyg för fräsning i Stål/Rostfritt/Gjutjärn/Titan/Ni-Co legeringar

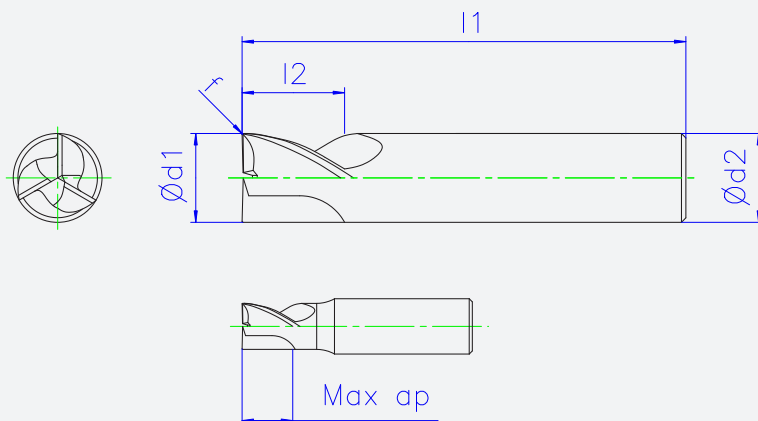

NEW

- 3-skärig
- Användbar skärlängd 1xD
- Belagd
- Allmän fräsning
- Variabel spånkanal
- Extra kort



## MBTF10 | ALSIDUR | Ø2,0-12,0

| Art.nr      | Ød1e8 | Ød2h6 | l1   | l2   | Max ap | fx45° | z | Info |
|-------------|-------|-------|------|------|--------|-------|---|------|
| • MBTF10040 | 4,0   | 6,0   | 40,0 | 4,0  | 4,0    | 0,1   | 3 | Cyl  |
| • MBTF10050 | 5,0   | 6,0   | 40,0 | 5,0  | 5,0    | 0,1   | 3 | Cyl  |
| • MBTF10060 | 6,0   | 6,0   | 40,0 | 6,0  | 6,0    | 0,15  | 3 | Cyl  |
| • MBTF10080 | 8,0   | 8,0   | 50,0 | 8,0  | 8,0    | 0,2   | 3 | Cyl  |
| • MBTF10100 | 10,0  | 10,0  | 50,0 | 10,0 | 10,0   | 0,2   | 3 | Cyl  |
| • MBTF10120 | 12,0  | 12,0  | 50,0 | 12,0 | 12,0   | 0,25  | 3 | Cyl  |

Info om skärdata, se sid 35.

● = Lagervara, ○ = Leveranstid 1-2 arbetsdagar

□ = Mellanliggande diameter eller hörnradie/fas tillverkas vid förfrågan.

