

# MBTA91 / MBTA91S - 2xD

Verktyg för fräsning i ALU/Mässing/Koppar/Plast

- 2-skärig
- Skärlängd 2xD
- Obelagd/belagd
- Allmän fräsning
- Reducerad 2,5-5xD
- Vibrationsdämpad

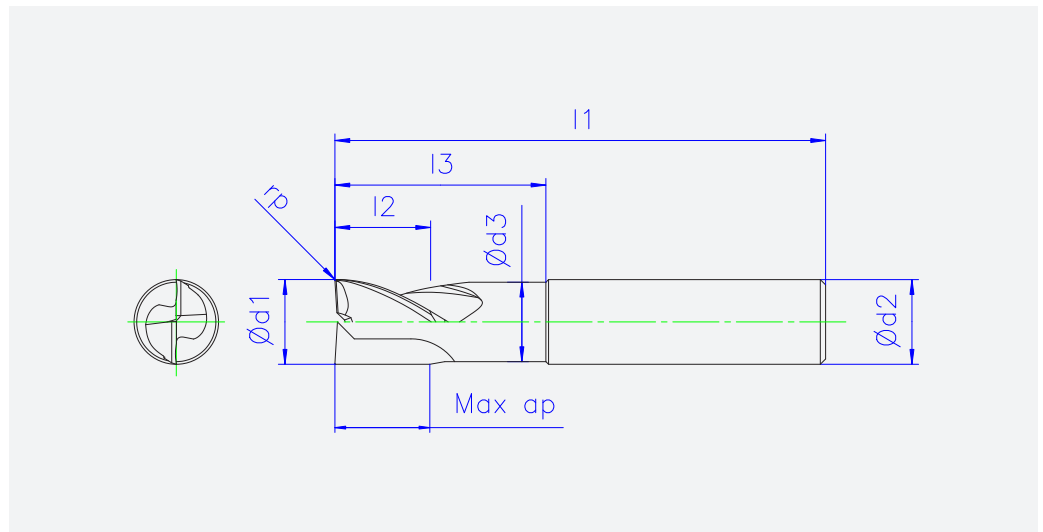

## MBTA91 | Ø2,0-20,0

Art.nr	Ød1h6	Ød2h6	Ød3	l1	l2	Max ap	l3	rp	z	Info
• MBTA91020010	2,0	6,0	1,9	57,0	5,0	5,0	10,0	0,10	2	Cyl
• MBTA91030010	3,0	6,0	2,9	57,0	7,0	7,0	15,0	0,10	2	Cyl
• MBTA91040010	4,0	6,0	3,8	57,0	8,0	8,0	15,0	0,10	2	Cyl
• MBTA91050010	5,0	6,0	4,8	57,0	10,0	10,0	21,0	0,10	2	Cyl
• MBTA91060010	6,0	6,0	5,8	57,0	12,0	12,0	23,0	0,10	2	Cyl
• MBTA91080010	8,0	8,0	7,8	64,0	16,0	16,0	25,0	0,10	2	Cyl
• MBTA91100010	10,0	10,0	9,6	72,0	20,0	20,0	30,0	0,10	2	Cyl
• MBTA91120015	12,0	12,0	11,5	84,0	24,0	24,0	36,0	0,15	2	Cyl
• MBTA91140015	14,0	14,0	13,5	84,0	18,0	18,0	35,0	0,15	2	Cyl
• MBTA91160015	16,0	16,0	15,0	93,0	32,0	32,0	42,0	0,15	2	Cyl
• MBTA91200020	20,0	20,0	19,0	101,0	40,0	40,0	52,0	0,20	2	Cyl

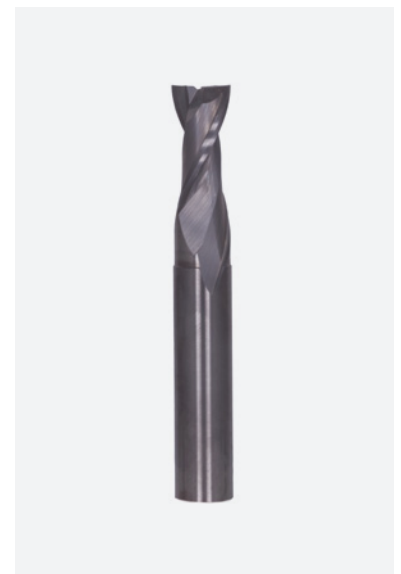

## MBTA91S | SilverTop | Ø6,0-20,0

Art.nr	Ød1h6	Ød2h6	Ød3	l1	l2	Max ap	l3	rp	z	Info
• MBTA91S060010	6,0	6,0	5,8	57,0	12,0	12,0	23,0	0,10	2	Cyl
• MBTA91S080010	8,0	8,0	7,8	64,0	16,0	16,0	25,0	0,10	2	Cyl
• MBTA91S100010	10,0	10,0	9,6	72,0	20,0	20,0	30,0	0,10	2	Cyl
• MBTA91S120015	12,0	12,0	11,5	84,0	24,0	24,0	36,0	0,15	2	Cyl
• MBTA91S140015	14,0	14,0	13,5	84,0	18,0	18,0	35,0	0,15	2	Cyl
• MBTA91S160015	16,0	16,0	15,0	93,0	32,0	32,0	42,0	0,15	2	Cyl
• MBTA91S200020	20,0	20,0	19,0	101,0	40,0	40,0	52,0	0,20	2	Cyl

SilverTop är en beläggning lämpad främst för >8%Si och gjutna material.  
Info om skärdata, se sid 39.

• = Lagervara, ◦ = Leveranstid 1-2 arbetsdagar

◻ = Mellanliggande diameter eller hörnradie/fas tillverkas vid förfrågan.